

## Safety information

Roxtec recommends that all installations are performed without facility operation. Follow national regulations and installation codes. Any action affecting the routed service should be performed according to manufacturer recommendations.

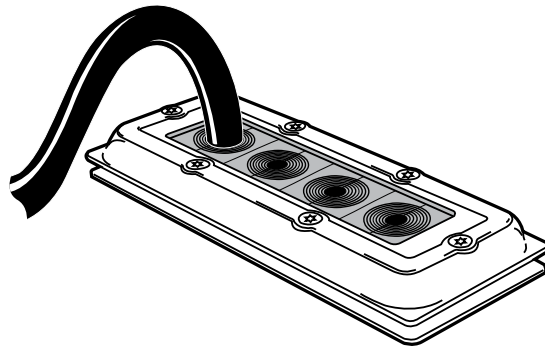

## Installation instructions Roxtec CF 16

## Components

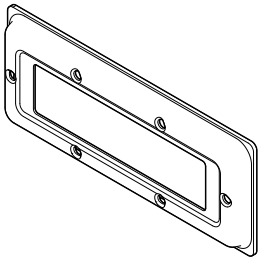

Front plate

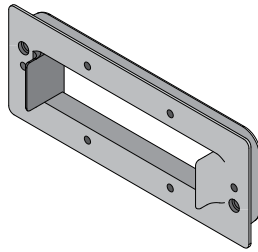

Compression rubber

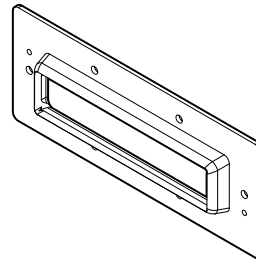

Back plate

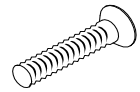

Torx screws M6  
6 pcs.



Cross-slotted screws M5  
2 pcs.



Roxtec Lubricant  
2 pcs.

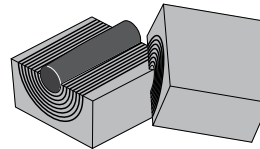

Roxtec CM sealing modules

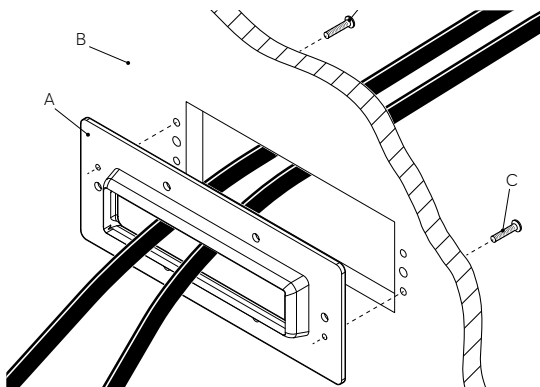

A: Back plate  
B: Cabinet/wall  
C: Cross-slotted screws M5

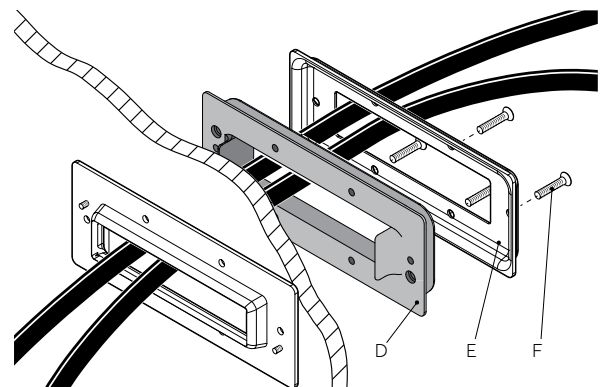

D: Compression rubber  
E: Front plate  
F: Torx screws M6

## Aperture dimensions and max wall thickness

Measures in millimeters (mm)

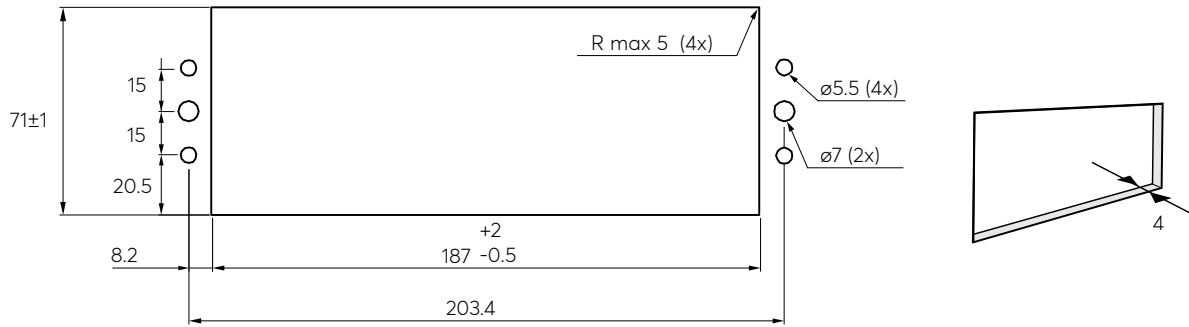

Max wall thickness

## Tools

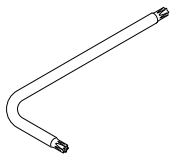

Allen key

## Installation

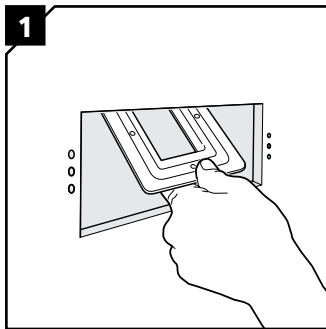

Insert the back plate from the installation side.

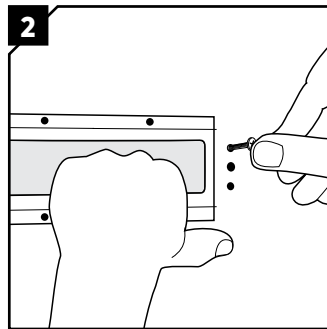

Fix the back plate with the two cross-slotted screws.

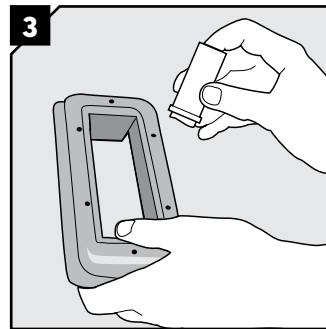

Thoroughly lubricate all surfaces of the compression rubber with Roxtec Lubricant.

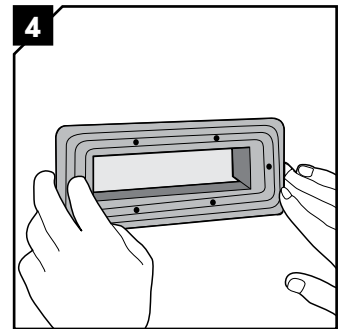

Place the compression rubber from the installation side.

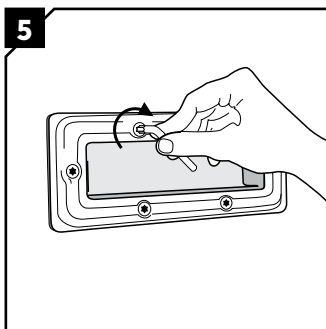

Fix the front plate parts loosely over the compression rubber with the torx screws.

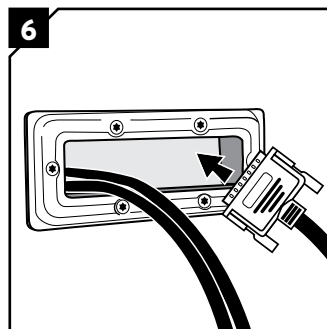

Insert the cables through the frame.

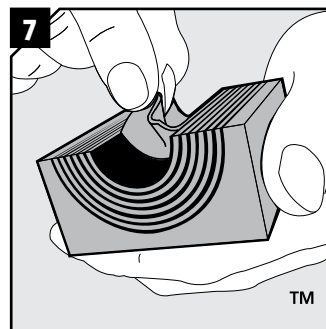

Adapt modules which are to hold cables or pipes by peeling off layers until you reach the gap seen in step 8. The halves may not differ by more than one layer.

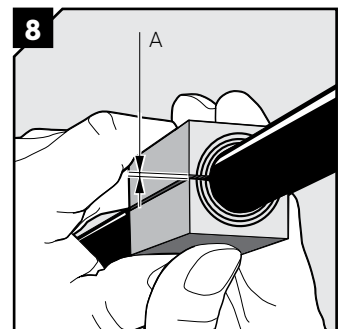

Achieve a 0.1-1.0 mm (A) gap between the two halves when held against the cable/pipe.

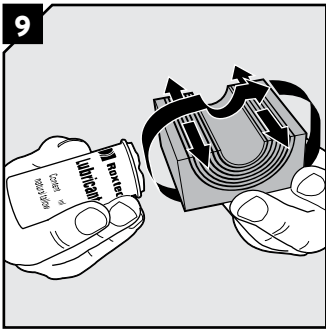

Lubricate the sealing surfaces of all modules.

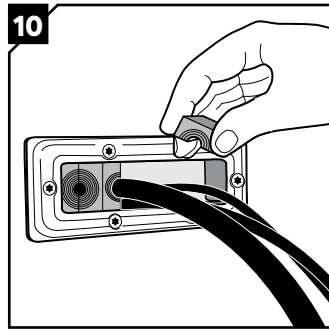

Insert the modules from the installation side.

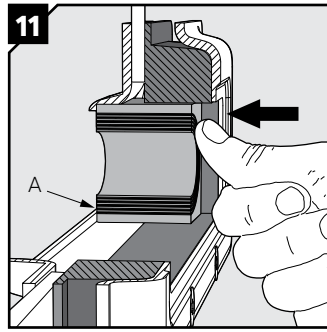

Fully insert the modules to the edge (A).

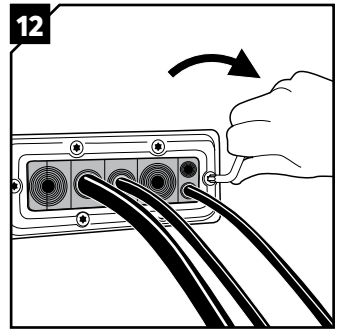

Firmly tighten the torx screws crosswise in small steps when all modules are in place. Always start with the short sides. Minimum tightening torque 8 Nm.

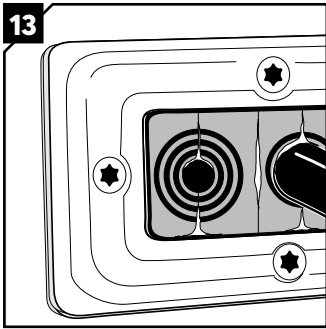

Visible excess Roptec Lubricant is a sign of good compression. Make sure that all modules are placed correctly and fully inserted after compression.

## Disassembly and reinstallation

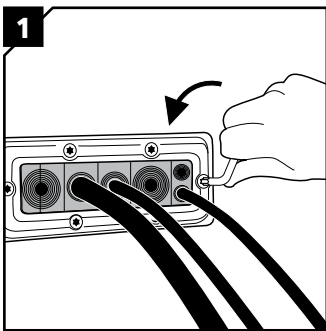

Untighten the torx screws crosswise in small steps.

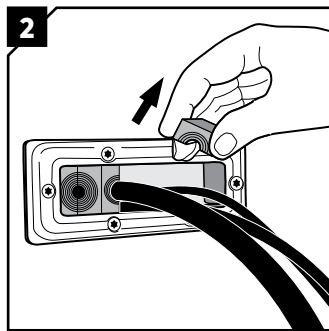

Remove modules needed.

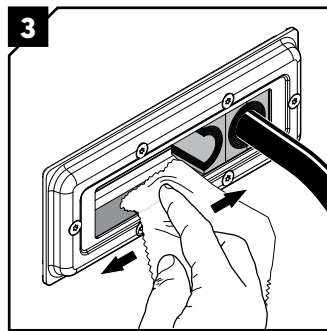

Clean the exposed packing space.

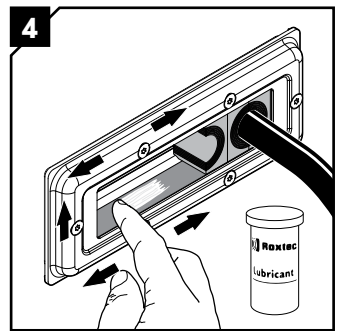

Lubricate the exposed packing space.

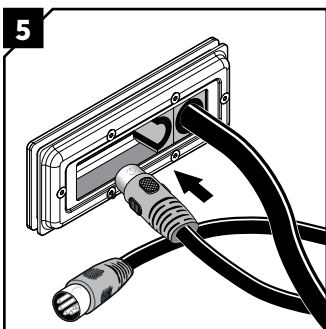

Continue the reinstallation from page 2, step 6.

## Note

- For optimum reliability, wait 24 hours or longer after installation before exposing the cables/pipes to strain or pressure.
- To be used with: CM components.
- Cables shall go straight through the frame.
- Approvals or certificates may include amendments or limitations related to this application.
- The latest version of this and related documents are found at roxtec.com.

## DISCLAIMER

"The Roxtec cable entry sealing system ("the Roxtec system") is a modular-based system of sealing products consisting of different components. Each and every one of the components is necessary for the best performance of the Roxtec system. The Roxtec system has been certified to resist a number of different hazards. Any such certification, and the ability of the Roxtec system to resist such hazards, is dependent on all components that are installed as a part of the Roxtec system. Thus, the certification is not valid and does not apply unless all components installed as part of the Roxtec system are manufactured by or under license from Roxtec ("authorized manufacturer"). Roxtec gives no performance guarantee with respect to the Roxtec system, unless (I) all components installed as part of the Roxtec system are manufactured by an authorized manufacturer and (II) the purchaser is in compliance with (a), and (b), below.

(a) During storage, the Roxtec system or part thereof, shall be kept indoors in its original packaging at room temperature.

(b) Installation shall be carried out in accordance with Roxtec installation instructions in effect from time to time.

The product information provided by Roxtec does not release the purchaser of the Roxtec system, or part thereof, from the obligation to independently determine the suitability of the products for the intended process, installation and/or use.

Roxtec gives no guarantee for the Roxtec system or any part thereof and assumes no liability for any loss or damage whatsoever, whether direct, indirect, consequential, loss of profit or otherwise, occurred or caused by the Roxtec systems or installations containing components not manufactured by an authorized manufacturer and/or occurred or caused by the use of the Roxtec system in a manner or for an application other than for which the Roxtec system was designed or intended.

Roxtec expressly excludes any implied warranties of merchantability and fitness for a particular purpose and all other express or implied representations and warranties provided by statute or common law. User determines suitability of the Roxtec system for intended use and assumes all risk and liability in connection therewith. In no event shall Roxtec be liable for indirect, consequential, punitive, special, exemplary or incidental damages or losses.\*



Roxtec International AB  
Box 540, 371 23 Karlskrona, SWEDEN  
PHONE +46 455 36 67 00, FAX +46 455 820 12  
EMAIL [info@roxtec.com](mailto:info@roxtec.com), [www.roxtec.com](http://www.roxtec.com)